

MLSP®



Mustang Sampling®

Mustang® Liquid Sample Pump

Item Number	Description
A	Instrument Air Supply Pressure Gauge
B	Instrument Air Regulator
C	Instrument Air Pressure Gauge
D	Pneumatic Controller
E	Pneumatic Pump
1	Sample Inlet
2	Sample Inlet Gauge
3	Bypass/Purge Valve
4	Particulate Filter
5	Pump Isolation Valve
6	Primer Port
7	Outlet Valve/Gauge
8	Safety Bypass Valve
9	Blow down Valve
10	Electric Pump

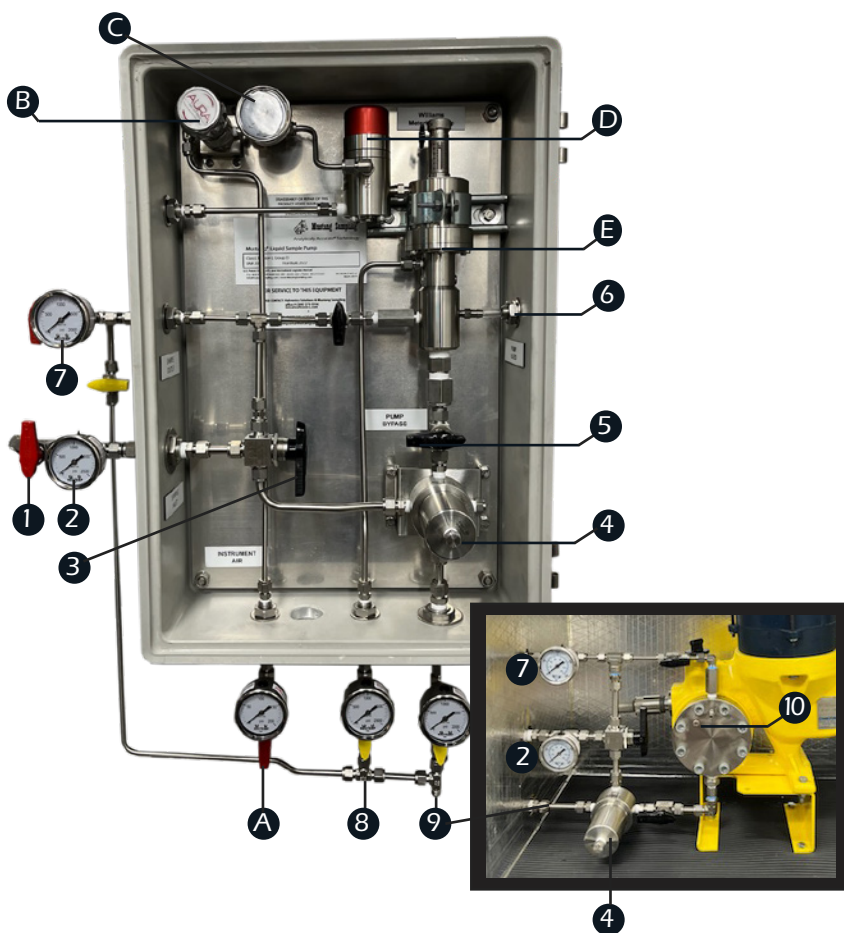

APPLICATION

The Mustang® Liquid Sample Pump (MLSP®) is a pneumatically driven device that allows the user to increase liquid sample pressure as part of an Analytically Accurate sample conditioning system (an optional electric pump is available upon request). The MLSP allows users to avoid the two-phase region of a fluid mixture by increasing the liquid pressure above the sample bubble point. Liquid samples may be vaporized downstream of the MLSP as part of a larger gas sampling and analysis system.

The Mustang Liquid Sample Pump generates sufficient residual pressure to allow for unfiltered reinjection of

the process fluid into the process pipeline. Liquid analysis lag time is greatly reduced compared to conventional techniques. The MLSP greatly improves the repeatability and accuracy of liquid sample analysis in custody transfer or process related measurements.

FEATURES

- Patent pending technology
- Rated for Class 1, Division 1, Group D Locations
- Steel latching enclosure
- Teflon composite seals
- Controller and Pump
 - Pneumatic or Electric
- Instrument air driven
- Speed loop return

BENEFITS

- No need for electrical classification (pneumatic only)
- Maintains liquid sample phase



NGL

PRODUCT DIMENSIONS

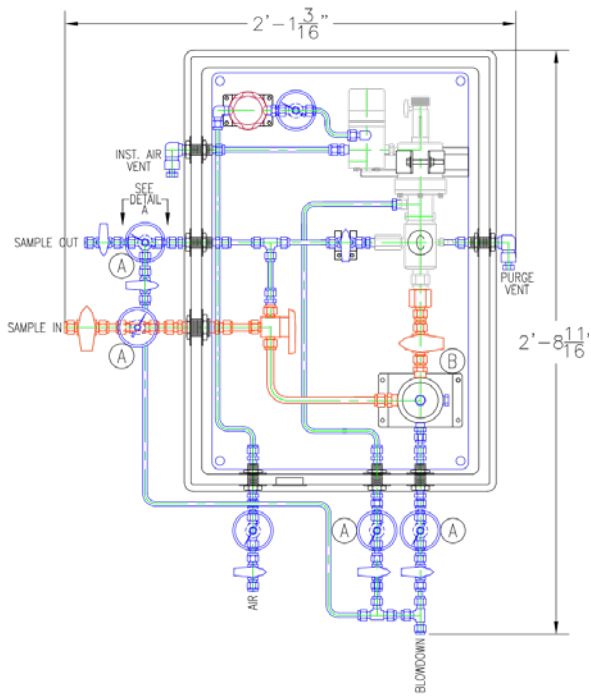

Pneumatic System

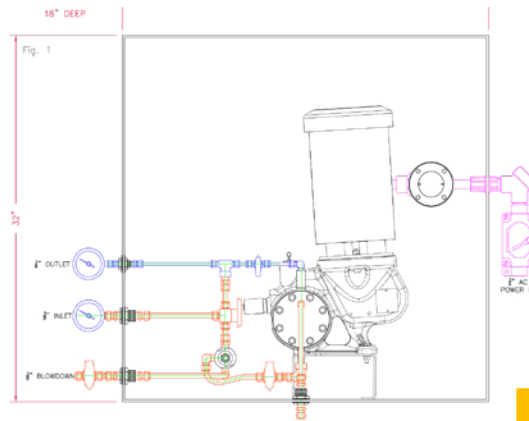

Electric System

Analytically Accurate®
TECHNOLOGY

About Mustang Sampling

Mustang Sampling, LLC is the innovator of Analytically Accurate® solutions within sample conditioning systems. We provide custom solutions of products and services globally to the Natural Gas, Natural Gas Liquids (NGL), Renewable Natural Gas (RNG), Liquefied Natural Gas (LNG) industries including Hydrogen Blending and Carbon Sequestration. Mustang Sampling continues to pioneer integrated control systems, allowing our customers to maintain phase stability from sample extraction at the source through sample analysis. Our products are continuously improved and subjected to the highest quality standards which provides our customers with the best sample conditioning solutions. Mustang Sampling, LLC
43 Ritmore Glen
Ravenswood, WV 26164
P: +1 304 273 5357
F: +1 304 273 2531

info@MustangSampling.com
www.MustangSampling.com

Copyright © 2017-2022 Mustang Sampling. All rights reserved. Mustang Sampling®, Mustang®, MLSP® and Analytically Accurate® are registered trademarks of Mustang Sampling, LLC.

No part of this publication may be reproduced in any material form without the written permission of Mustang Sampling, LLC.

MS-CSMLSP:v5-EN-P August 2022
Supersedes: MS-CSMLSPv4-EN-P

PRODUCT SPECIFICATIONS

Maximum Allowable Operating Pressure	750 to 9000 psig @ -30°F to 180°F (52 to 621 bar @ -35°C to -118°C)
Wetted Materials	316 SS
Maximum Volume	8.71 LPH
Strokes Per Minute	1 to 45
Stroke Size	1 to 3.2 cc
Maximum Actuation Air Consumption	1150 SCF per day at 100 PSIG (7 BAR)
Cabinet Construction Options	GRP Hotpressed Glass Fiber Reinforced Polyester SS Stainless Steel
Controller and Pump Type	PN Pneumatic E Electric

Use the bold alpha-numeric characters from the table above to build your model number:

MLSP - -
 Cabinet Controller and Pump